

nano

Twin Tower Desiccant Compressed Air Dryers

FLOW CAPACITY: 70 to 6,000 scfm

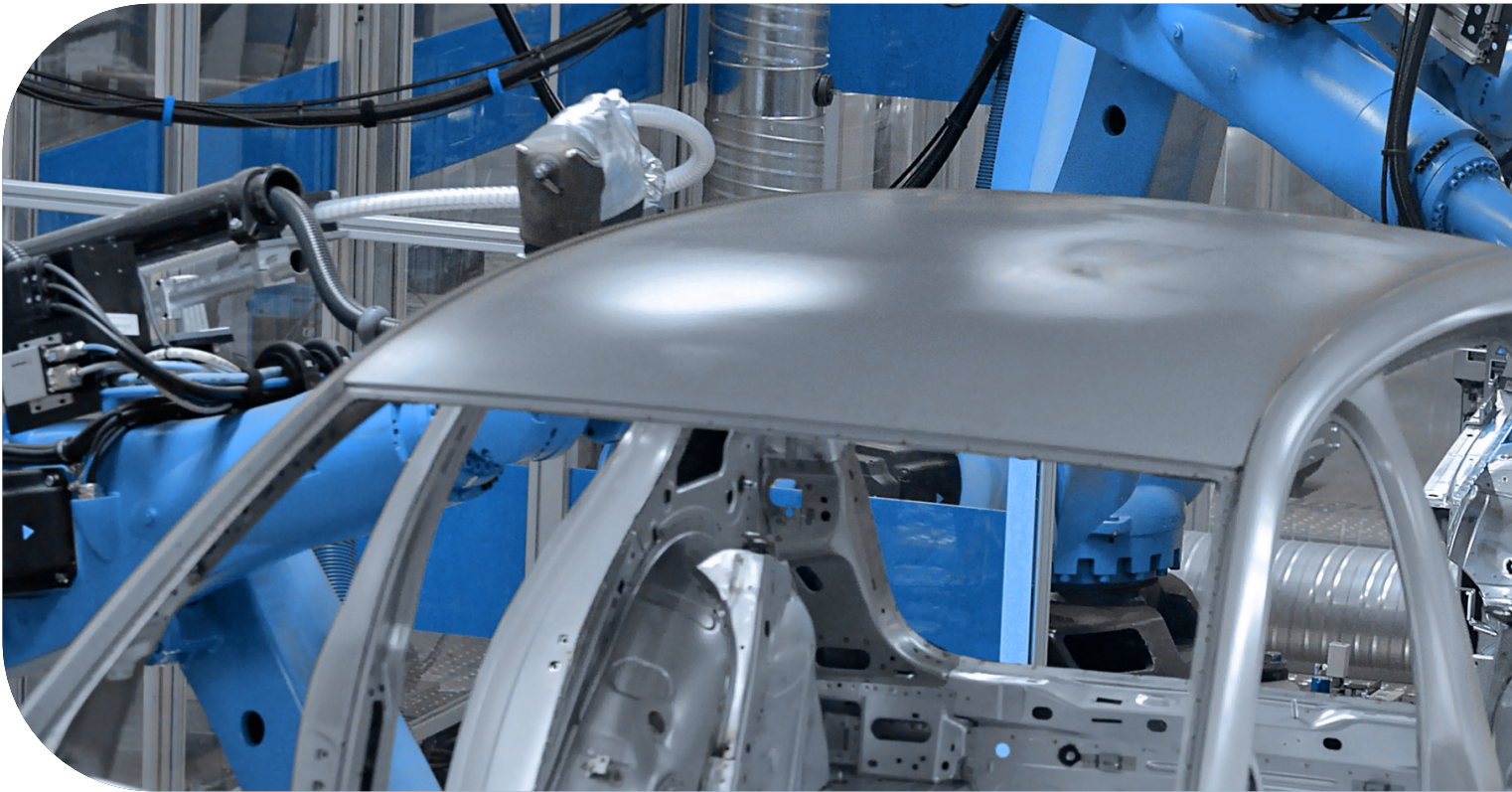



“We needed special options on our desiccant dryer. nano helped guide us to make informed decisions and built the perfect dryer for our company.”

A Parts Manufacturer - Southwestern USA

Clean, dry compressed air is essential in every efficient and profitable manufacturing operation worldwide. Ambient air contains high levels of moisture, dust, hydrocarbons and other contaminants and, when left untreated, the results are corrosion, bacteria, mold growth and freezing within your compressed air lines. This contamination can cause damage to downstream equipment and lead to increased maintenance, downtime and product spoilage.

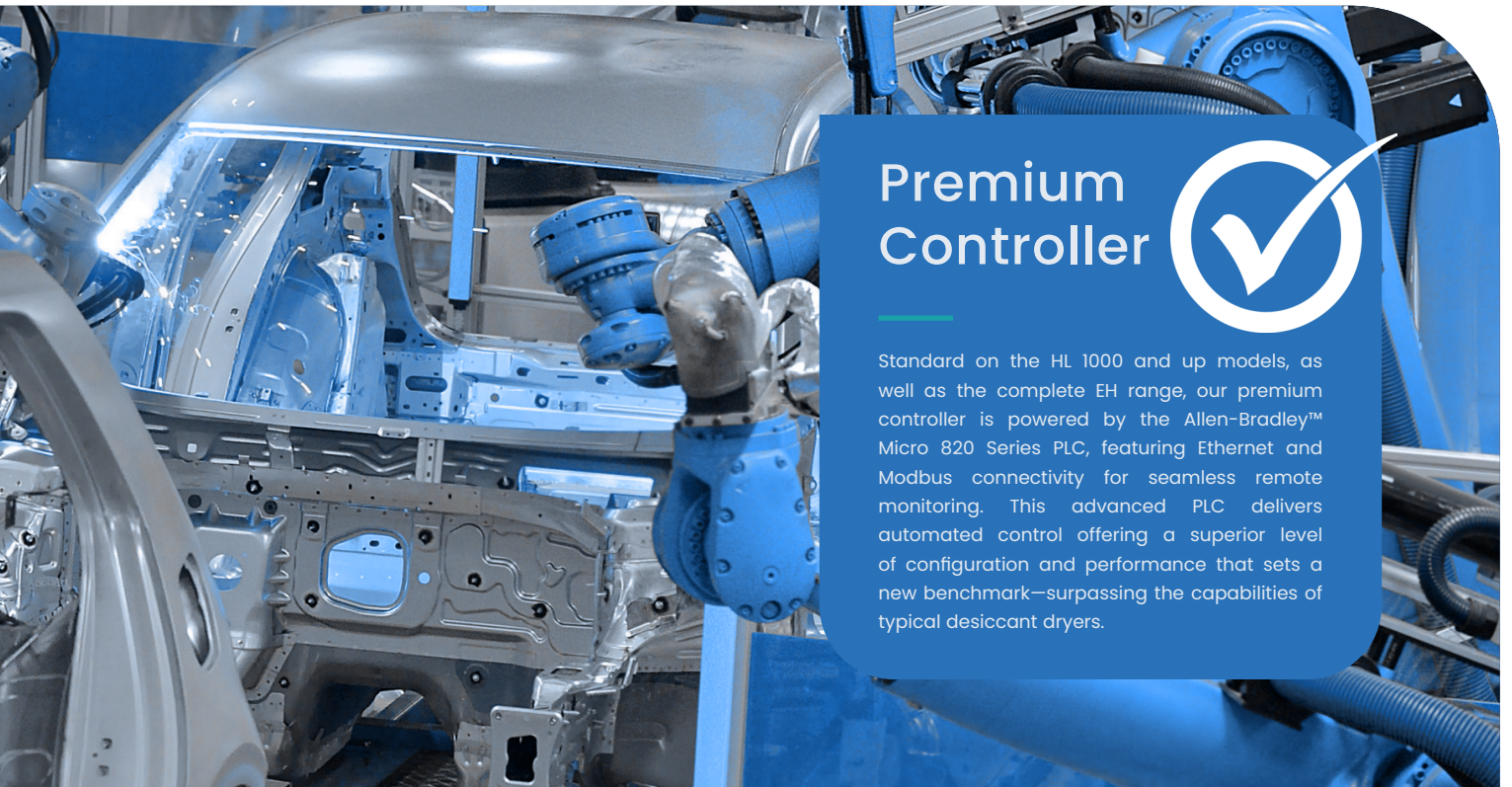

Premium Controller



Standard on the HL 1000 and up models, as well as the complete EH range, our premium controller is powered by the Allen-Bradley™ Micro 820 Series PLC, featuring Ethernet and Modbus connectivity for seamless remote monitoring. This advanced PLC delivers automated control offering a superior level of configuration and performance that sets a new benchmark—surpassing the capabilities of typical desiccant dryers.

While compressed air filters will remove solid particulate, liquids and aerosols, they cannot remove the moisture that remains in the form of vapor. This vapor condenses into liquid water throughout your compressed air system as the pressure and temperature of the compressed air changes.

nano D⁵ Twin Tower Desiccant Compressed Air Dryers

- Removal of water vapor by lowering the pressure dew point of your compressed air stream to -40°F to ensure a continuous supply of dry air.
- Low pressure drop and consistent dew point performance
- Designed for the most demanding applications.
- Flexibility to build a complete compressed air solution to match the requirements of the customer.





Which Dryer is Right for You?

HL Heatless

Use expanded dry purge air to regenerate desiccant beds

- Lowest initial investment
- Require the most purge air at 15%
- -40°F dew point as standard for ISO Class 2 applications



EH Externally Heated

Use an electric heater to heat the dry purge air to regenerate the desiccant beds

- Mid-priced initial investment
- Excellent ROI
- Use less purge air than heatless at approximately 6-8%
- -40°F dew point as standard for ISO Class 2 applications

ABP Blower Purge

Use a combination of an ambient blower and heater followed by dry purge air to regenerate the desiccant beds.

- Further reduces (or even eliminates) purge air usage to approximately 0-2% averaged over 4-hour cycle for dry air cooling.
- Dry air cooling can be turned off allowing zero air loss operation.
- -40°F dew point as standard for ISO Class 2 applications
- Higher initial investment
- Fastest ROI





How it Works

Heatless Range

In a twin tower desiccant air dryer, one tower is on-line drying the compressed air while the other is off-line regenerating, which means it is eliminating the water vapor it has collected so it can be used to dry again. The two towers switch back and forth so one is always drying while the other is regenerating or in standby.

The nano D⁵ branded twin tower desiccant dryers remove moisture from your compressed air system in the same way and to the same exacting standards of performance and reliability. The difference is how they regenerate and the amount of compressed air and/or power required to do so.

- A** 0.01 micron pre-filter removes all particulate, liquid water and oil aerosols to 0.01 ppm.
- B** Clean, saturated air enters the inlet valve which directs it to one of the desiccant towers.
- C** Compressed air travels through tower A for 5 minutes and moisture vapor is adsorbed to -40°F PDP or better.
- D** A final filter removes particulate to 1.0 micron or better
- E** ~15% purge air expands through an orifice and regenerates tower B (HL Range).
- F** After, the purge exhaust valve closes and tower B repressurizes and is ready for adsorption to begin.
- G** At the 5-minute mark (fixed cycle), tower A exhaust valve opens to regenerate. A PLC controls all operations.
- H** Compressed air is expensive but nano dryers can be fitted with an energy savings device to save air and save money. By measuring actual pressure dew point, the PLC will extend the dryer cycle reducing compressor energy, wasted purge air and valve wear and tear.

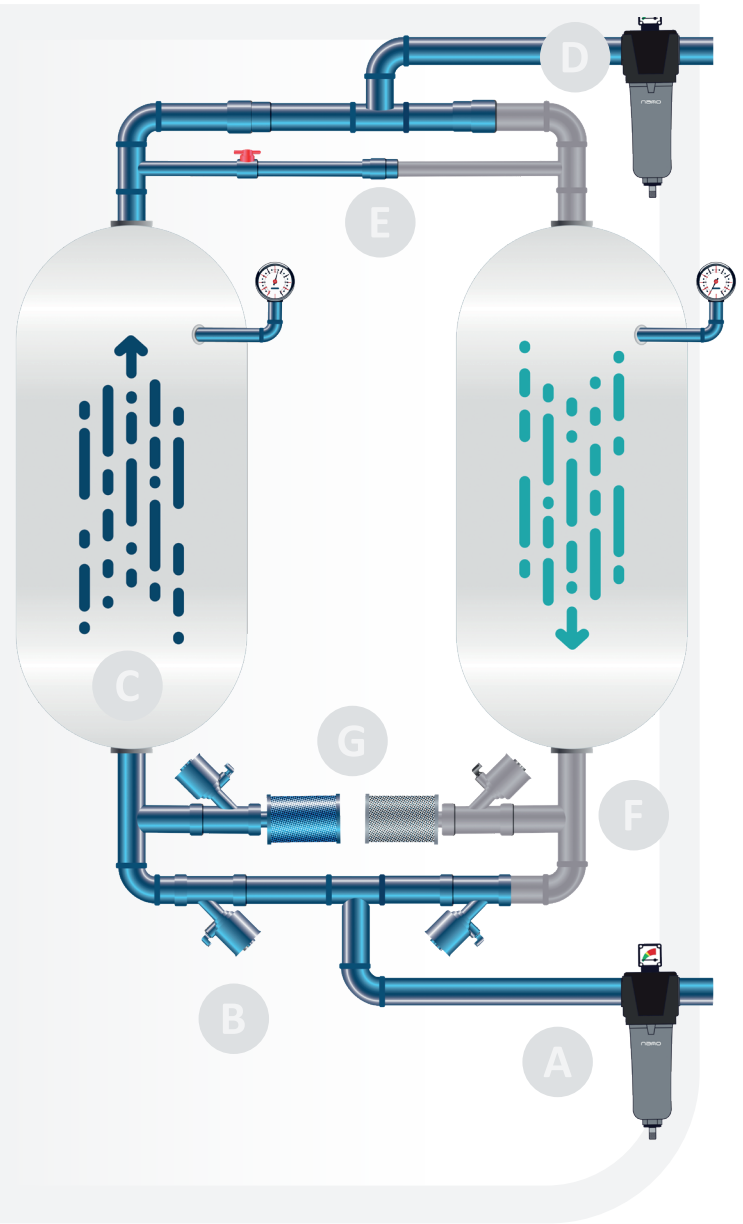

Features

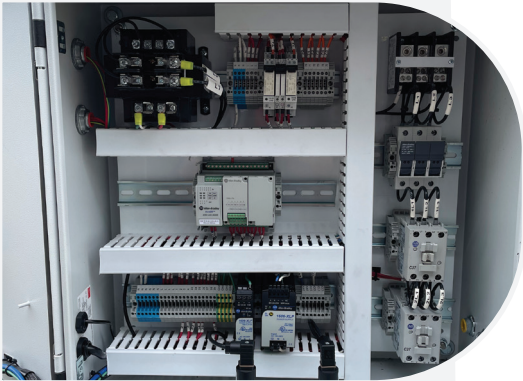

PLC Controlled Operation

- The dryer is operated by a robust and reliable PLC control system offering valuable features including 'power on', 'hours run' and 'service required indicators'.
- Memory retention built into the PLC enables the controller to pick up where it left off in the drying cycle, ensuring consistently clean and dry air downstream.
- Compressor synchronization is a standard energy saving feature on HL range which starts and stops the dryer with a signal from the compressor to eliminate purge loss when drying is not required.
- NEMA 4 control panel
- Models HL 1000 and up and complete EH range include our premium controller as standard.

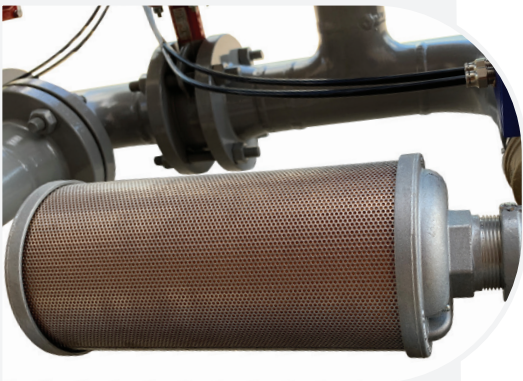

Low Noise Exhaust Mufflers

- Specifically designed to minimize the noise of depressurization and purge exhaust.
- High flow design improves regeneration.

Low Watt Density Heater (EH & ABP ranges)

- Regeneration circuit is fully insulated for maximum efficiency.
- Specifically designed for a long and dependable operating life in harsh industrial environments.



Secondary Heater Contactor (EH & ABP Ranges)

- Provides protection against overheating in the event of a primary contactor failure.

Regenerative Blower (ABP Range)

- Utilizes atmospheric air for regeneration.
- Easy maintenance and a rugged construction with TEFC premium motor that includes filtered air intake.
- Vortex regenerative blower (models 2500 scfm and below); centrifugal blower (models 3000 scfm and larger).



Features

Pneumatically Operated Angle-Body Piston Valves

- Two-way valves with stainless steel internals and Teflon™ seats ensure reliable field proven performance.
- Used for inlet valves on models HL 0070 to HL 0750.

High Performance Butterfly Valves

- Pneumatic actuators ensure precise proportional control and a bubble tight seal; no rubber seals.
- Rugged stainless steel disk and Teflon® seats combined with a low pressure drop design.
- Used for inlet valves on HL range and EH ranges; 800 scfm and larger for ABP range.

Stainless Steel Spring Check Valves

- Metal on metal seats for reliable operation, even high temperature operation
- Provide worry-free operation and minimal maintenance.

Back-Up Heatless Mode (EH & ABP Ranges)

- Peace of mind in the event of heater failure

Parallel Cooling Mode (ABP Range)

- Features a unique parallel cooling mode to further reduce the heat and dew point spike prior to tower switch over. During the parallel cooling mode, both inlet valves are open and divert half-load to each tower, further cooling the previously regenerated desiccant bed with a larger volume of air.
- Maximum savings with accurate dew point control

High Quality Construction

- ASME coded pressure vessels
- UL/cUL compliant
- Activated alumina desiccant made in the USA
- Lifting lugs and/or fork lift pockets on all products





Upgrades

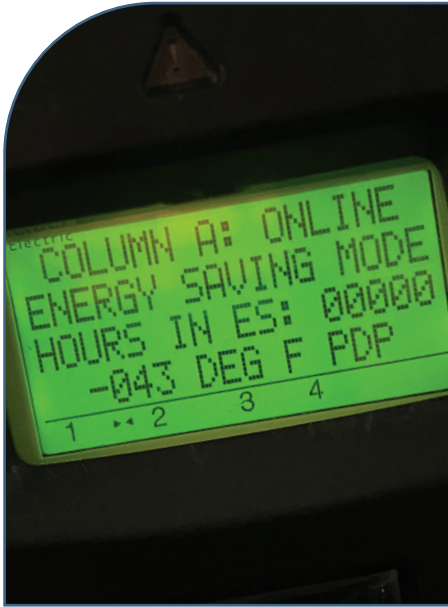

Energy Saving Dew Point Control Option

- Standard on EH and ABP ranges
- With this option, a dew point sensor is incorporated into the dryer providing the ultimate in energy and power savings.
- Outlet dew point is constantly monitored allowing the cycle time to be adjusted depending on the actual moisture load saving valuable purge air on all styles of dryers.
- Saves additional energy on heated dryers by reducing heater on-time and blower run-time.
- The -ES option reduces valve actuation.

Validated Compressed Air Filter Packages

- nano pre and after filtration packages standard on HL, EH and ABP ranges.
- nano F² flanged filters used on models above 1500 scfm
- Multiple bypass options available

Other Options Include

- Low ambient kits for outdoor environments
- Special paint finishes
- Enhanced corrosion allowances for harsh ambient conditions
- NEMA 7 explosion-proof designs
- Available up to 6000 psig maximum pressure
- Rental packages with air driven controls and after cooler available
- Custom designs to comply with specifications welcome



HL Heatless Specifications

MODEL	INLET & OUTLET ⁽¹⁾	RATED FLOW ⁽²⁾	DIMENSIONS (INCHES)			APPROX. WEIGHT ⁽³⁾	INCLUDED FILTRATION ⁽⁴⁾	
	NPT(F)/FLG	SCFM	W	D	H	LBS	PRE FILTER	AFTER FILTER
HL 0070	¾"	70	30.5	22.6	71.5	275	GFN0085M01	GFN0085M1
HL 0100	1"	100	34.0	25.5	74.0	300	GFN0105M01	GFN0105M1
HL 0150	1"	150	34.0	25.5	74.0	415	GFN0175M01	GFN0175M1
HL 0200	1 ½"	200	38.5	32.8	83.5	540	GFN0325M01	GFN0325M1
HL 0250	1 ½"	250	38.5	32.8	83.5	590	GFN0325M01	GFN0325M1
HL 0300	1 ½"	300	48.0	35.5	84.1	600	GFN0325M01	GFN0325M1
HL 0350	2"	350	48.8	42.3	84.4	735	GFN0450M01	GFN0450M1
HL 0450	2"	450	48.8	42.3	84.4	1000	GFN0450M01	GFN0450M1
HL 0500	2"	500	50.8	42.3	86.4	1100	GFN0700M01	GFN0700M1
HL 0600	2"	600	50.8	42.3	86.5	1300	GFN0700M01	GFN0700M1
HL 0750	2"	750	53.0	42.3	87.3	1500	GFN0850M01	GFN0850M1
HL 1000	3"	1000	66.0	61.0	94.8	2600	GFN1250M01	GFN1250M1
HL 1250	3"	1250	70.0	61.0	99.8	3000	GFN1250M01	GFN1250M1
HL 1500	3"	1500	70.0	61.0	99.2	3400	GFN1500M01	GFN1500M1
HL 2000	4"	2000	102.0	64.0	110.8	4600	NFZ2500M01	NFZ2500M1
HL 2500	4"	2500	102.0	64.9	110.8	5000	NFZ2500M01	NFZ2500M1
HL 3000	6"	3000	113.8	65.3	120.8	6500	NFZ3500M01	NFZ3500M1

SPECIFICATIONS	STANDARD	OPTIONAL
Maximum particle size (ISO class)	class 2	class 1
Maximum water content (ISO class)	class 2	-
Minimum / design / maximum operating pressure range (HL 0070 to HL 1500) (psig)	60 / 100 / 180	58 to 250
Minimum / design / maximum operating pressure range (HL 2000 to HL 3000) (psig)	60 / 100 / 135	58 to 250
Minimum / design / maximum ambient temperature (°F)	38 / 100 / 120	20 / 100 / 120
Minimum / design / maximum inlet temperature (°F)	38 / 100 / 120	-
Power supply requirements	115V / 1Ph / 60Hz	230V / 1Ph / 60Hz & 12V DC

PRESSURE CORRECTION FACTORS ⁽⁷⁾									
Operating pressure (psig)	60	70	80	90	100	110	130	140	150
Correction factor	0.65	0.74	0.83	0.91	1.00	1.04	1.12	1.16	1.20

TEMPERATURE CORRECTION FACTORS ⁽⁷⁾									
Inlet temperature (°F)	70	80	90	100	105	110	115	120	
Correction factor	1.12	1.10	1.06	1.00	0.93	0.86	0.80	0.75	

- 2" and below are NPT(F) threaded. 3" and above are flanged. All units with 3" piping and above will be ansi welded pipe
- In compliance with ADF 100 specifications for compressed air dryers: inlet temperature: 100°F, ambient temperature: 100°F, inlet pressure dew point: -40°F. For all other conditions refer to the correction factors or contact support@airandgassolutions.com.
- Approx. weight for all models does not include desiccant installed.
- Pre and after filters mounted on dryer as standard.
- Per ISO 8573.1:2010
- Maximum working pressure for all models is 150 psig. For higher pressures, contact support@airandgassolutions.com.
- To be used as a rough guide only. All applications should be confirmed by nano. Contact nano for sizing assistance.
- All models are UL/cUL compliant
- All models have ASME coded pressure vessels. CRN vessels for models HL 1500 and small. For other approvals, consult support@airandgassolutions.com.
- For sizes above 3000 scfm and pressure below 60 psig, please contact support@airandgassolutions.com.

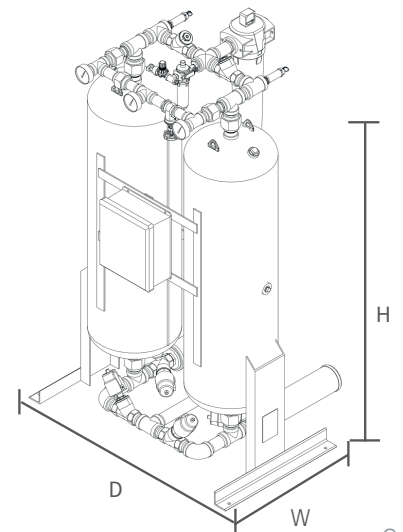



EH Externally Heated Specifications

MODEL	INLET & OUTLET ⁽¹⁾	RATED FLOW ⁽²⁾	HEATER	DIMENSIONS (INCHES)			APPROX. WEIGHT ⁽³⁾	INCLUDED FILTRATION ⁽⁴⁾	
	NPT(F)/FLG	SCFM	Kw	W	D	H	LBS	PRE FILTER	AFTER FILTER
EH 0150	1"	150	3	58	31	79	1000	GFN0175M01	GFN0175M1
EH 0250	1 ½"	250	4	60	31	88	1500	GFN0325M01	GFN0325M1
EH 0350	2"	350	6	64	47	91	2000	GFN0450M01	GFN0450M1
EH 0500	2"	500	7	64	47	91	2300	GFN0700M01	GFN0700M1
EH 0750	2"	750	11	72	50	92	2700	GFN0850M01	GFN0850M1
EH 1000	3"	1000	15	80	62	95	4100	GFN1250M01	GFN1250M1
EH 1250	3"	1250	18	85	62	100	4900	GFN1250M01	GFN1250M1
EH 1500	3"	1500	22	85	62	100	5200	GFN1500M01	GFN1500M1
EH 2000	4"	2000	33	96	87	111	7800	NFZ2500M01	NFZ2500M1
EH 2500	4"	2500	37	96	87	111	9500	NFZ2500M01	NFZ2500M1
EH 3000	6"	3000	45	114	92	121	11500	NFZ3000M01	NFZ3000M1

SPECIFICATIONS	STANDARD	OPTIONAL
Maximum particle size (ISO class) ⁽⁵⁾	class 2 (1 micron)	class 1 (0.01 micron)
Maximum water content (ISO class) ⁽⁵⁾	class 2 (-40°F PDP)	-
Minimum / design / maximum operating pressure range (psig)	70 / 100 / 180 (Models EH 0150 to EH 1500) 70 / 100 / 135 (Models EH 2000 to EH 3000)	58 to 250
Minimum / design / maximum ambient temperature (°F)	38 / 100 / 120	20 / 100 / 120
Minimum / design / maximum inlet temperature (°F)	38 / 100 / 120	-
Power supply requirements	460V/3Ph/60Hz	575V/3Ph/60Hz

PRESSURE CORRECTION FACTORS ⁽⁶⁾									
Operating pressure (psig)	60	70	80	90	100	110	130	140	150
Correction factor	0.65	0.74	0.83	0.91	1.00	1.04	1.12	1.16	1.20

TEMPERATURE CORRECTION FACTORS ⁽⁶⁾								
Inlet temperature (°F)	70	80	90	100	105	110	115	120
Correction factor	1.12	1.10	1.06	1.00	0.93	0.86	0.80	0.75

- (1) 2" and below are NPT(F) threaded. 3" and above are flanged. All units with 3" piping and above will be ANSI welded pipe
- (2) In compliance with ADF 100 specifications for compressed air dryers: inlet temperature: 100°F, ambient temperature: 100°F, inlet pressure dew point: -40°F. For all other conditions refer to the correction factors or contact support@airandgassolutions.com.
- (3) Approx. weight for all models includes desiccant; units 1000 scfm and above ship with desiccant loose.
- (4) Pre and after filters mounted on dryer as standard.
- (5) Per ISO 8573.1:2010
- (6) To be used as a rough guide only. All applications should be confirmed by nano. Contact nano for sizing assistance.
- (7) For sizes above 3000 scfm and pressure below 60 psig, please contact support@airandgassolutions.com.
- (8) All models are UL/cUL compliant.
- (9) All models have ASME coded pressure vessels. Models EH 1500 and below have CRN vessels. For other approvals, consult support@airandgassolutions.com.

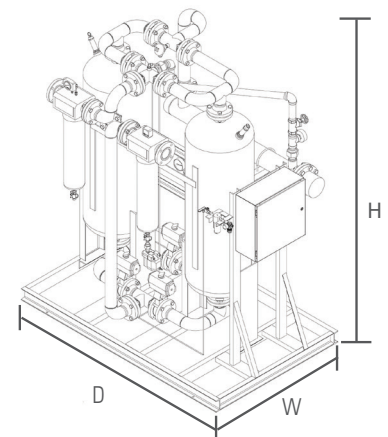



ABP Blower Purge Specifications

MODEL	INLET & OUTLET ⁽¹⁾		RATED FLOW ⁽²⁾		HEATER		BLOWER		DIMENSIONS (INCHES)			APPROX. WEIGHT ⁽³⁾		INCLUDED FILTRATION ⁽⁴⁾	
	FLG	SCFM	Kw	HP	W	D	H	LBS	PRE FILTER	AFTER FILTER					
ABP 800	3"	800	18	5	60	87	100	3600	GFN0850M01	GFN0850M1					
ABP 1000	3"	1000	22	5	60	90	100	4500	GFN1250M01	GFN1250M1					
ABP 1200	3"	1200	27	7.5	61	98	105	5400	GFN1250M01	GFN1250M1					
ABP 1400	3"	1400	32.5	10	70	105	106	6800	GFN1500M01	GFN1500M1					
ABP 1600	4"	1600	37	10	81	106	107	7500	NFZ2500M01	NHT1600M1					
ABP 2000	4"	2000	45	10	81	106	116	9000	NFZ2500M01	NFZ2500M1					
ABP 2500	4"	2500	52	15	83	128	116	10700	NFZ2500M01	NFZ2500M1					
ABP 3000	6"	3000	64	15	111	131	127	13400	NFZ3500M01	NFZ3500M1					
ABP 3500	6"	3500	78	15	105	134	120	15600	NFZ3500M01	NFZ3500M1					
ABP 4000	6"	4000	90	15	106	147	128	17900	NFZ4000M01	NFZ4000M1					
ABP 5000	6"	5000	110	20	109	163	138	22300	NFZ5000M01	NFZ5000M1					
ABP 6000	8"	6000	120	25	118	169	147	26800	NFZ7500M01	NFZ7500M1					

SPECIFICATIONS	STANDARD	OPTIONAL
Maximum particle size (ISO class) ⁽⁵⁾	class 2 (1 micron)	class 1 (0.01 micron)
Maximum water content (ISO class) ⁽⁵⁾	class 2 (-40°F PDP)	-
Minimum / design / maximum operating pressure range (psig) ⁽⁶⁾	60 / 100 / 150	58 to 250
Minimum / design/ maximum ambient temperature (°F)	38 / 100 / 120	-
Minimum / design / maximum inlet temperature (°F)	38 / 100 / 120	-
Power supply requirements	460V AC/60Hz	-

PRESSURE CORRECTION FACTORS ⁽⁷⁾										
Operating pressure (psig)	60	70	80	90	100	110	130	140	150	
Correction factor	0.65	0.73	0.82	0.91	1.00	1.09	1.27	1.35	1.44	

TEMPERATURE CORRECTION FACTORS ⁽⁷⁾									
Inlet temperature (°F)	70	80	90	100	105	110	115	120	
Correction factor	1.20	1.15	1.10	1.00	0.90	0.80	0.70	0.60	

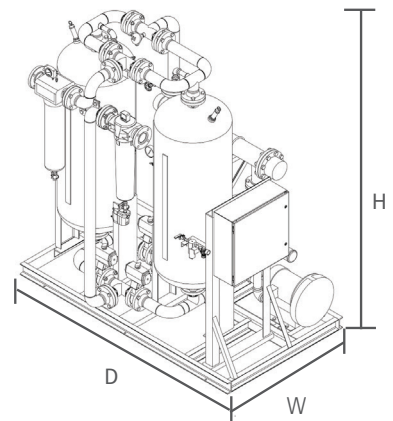

- (1) All units are flanged, ANSI welded pipe.
- (2) In compliance with ADF 100 specifications for compressed air dryers: Inlet temperature: 100°F, ambient temperature: 100°F, inlet pressure dew point: -40°F. For all other conditions refer to the correction factors or contact support@airandgassolutions.com.
- (3) Approx. weight for all models includes desiccant; units 800 scfm and above ship with desiccant loose.
- (4) Pre and after filters mounted on dryer as standard.
- (5) Per ISO 8573.1:2010
- (6) Maximum working pressure for all models is 150 psig. For higher pressures, contact support@airandgassolutions.com.
- (7) To be used as a rough guide only. All applications should be confirmed by nano. Contact nano for sizing assistance.
- (8) All models are UL/cUL compliant.
- (9) All models have ASME coded pressure vessels. For other approvals, consult support@airandgassolutions.com.

Experience.
Customer.
Service.



nano-purification solutions
www.nano-purification.com

Headquarters

United States
Charlotte, North Carolina
Phone: +1 704 897 2182
E-mail: support@airandgassolutions.com

United States
Maryville, Tennessee
Phone: +1 704 897 2182
E-mail: support@airandgassolutions.com

Canada
St. Catharines, Ontario
Phone: +1 905 684 6266
E-mail: canadasupport@airandgassolutions.com

Singapore
Singapore
Phone: +65 6748 7988
E-mail: support.asia@nano-purification.com

United Kingdom
Gateshead, Tyne and Wear
Phone: +44 (0) 191 497 7700
E-mail: sales_uk@nano-purification.com

