

stainless steel high pressure filters

FEATURES

- comprehensive range of stainless steel filters ideal for a wide variety of high pressure applications
- manufactured from high grade 316 stainless steel
- 21 models across 3 pressure ranges offering flows up to 2000 scfm and pressure ratings up to 5000 psig
- choose from 5 different element grades including 25, 5, 1 and 0.01 micron coalescing and/or dust filtration and activated carbon plus a water separator option
- the 725 psig range incorporates an innovative push-fit element design to ensure optimum sealing and mechanical strength
- the 1450 and 5000 psig ranges incorporate elements with corrosion resistant stainless steel end caps
- custom engineered filter media designed to provide low air velocity preventing oil carry over for high efficiency filtration with minimal pressure drop
- manufactured in an ISO 9001 approved facility and tested in accordance with ISO 8573.1:2010
- applications include chemical, food and beverage, manufacturing, military, oil and gas and pharmaceuticals



condensate drain options

select from stainless steel manual drains or stainless steel timed solenoid drains to suit your requirement



element design

725 psig range element end caps are color coded for easy identification; 1450 and 5000 psig ends caps are stainless steel

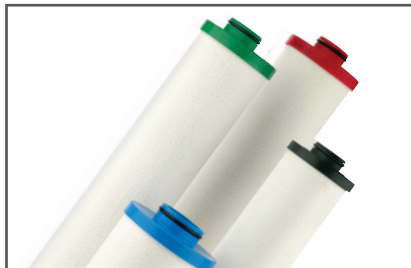

nano-purification solutions
charlotte, north carolina
united states

nano-purification solutions
new bethlehem, pennsylvania
united states

nano-purification solutions
st. catharines, ontario
canada

nano-purification solutions
gateshead, tyne and wear
united kingdom

nano-purification solutions
krefeld, germany

tel: 704.897.2182
fax: 704.897.2183
email: support@n-psi.com
web: www.n-psi.com

SPECIFICATIONS

filter model	inlet & outlet		rated flow ⁽¹⁾		dimensions (inches)				approx. weight	replacement element
	NPT	scfm	Nm ³ /h	A	B	C	D	lbs		
N50SS (725 psig)										
N50SS 0060 (grade)	¼"	60	100	3.35	0.71	6.69	2.95	3.7	E50SS 0060 (grade)	
N50SS 0120 (grade)	⅜"	120	200	3.35	0.71	8.07	3.94	4.4	E50SS 0120 (grade)	
N50SS 0200 (grade)	½"	200	340	3.35	0.71	10.04	3.94	4.8	E50SS 0200 (grade)	
N50SS 0300 (grade)	¾"	300	500	4.33	1.06	10.63	5.91	8.8	E50SS 0300 (grade)	
N50SS 0600 (grade)	1"	600	1000	4.33	1.06	16.54	11.81	11.0	E50SS 0600 (grade)	
N50SS 1000 (grade)	1½"	1000	1700	5.91	1.77	20.67	11.81	33.0	E50SS 1200 (grade)	
N50SS 1200 (grade)	2"	1200	2040	5.91	1.77	20.67	11.81	33.0	E50SS 1200 (grade)	
N50SS 2000 (grade)	2"	2000	3400	5.91	1.77	32.48	19.69	46.2	E50SS 2000 (grade)	
N100SS (1450 psig)										
N100SS 0060 (grade)	¼"	60	100	2.56	0.79	5.31	2.76	7.0	E100SS 0060 (grade)	
N100SS 0185 (grade)	½"	185	315	2.56	0.79	9.84	7.09	12.3	E100SS 0185 (grade)	
N100SS 0270 (grade)	¾"	270	460	3.15	0.98	10.83	9.84	13.4	E100SS 0270 (grade)	
N100SS 0400 (grade)	1"	400	680	5.31	1.02	10.43	11.81	23.1	E100SS 0400 (grade)	
N100SS 0700 (grade)	1"	700	1200	5.31	1.02	16.49	11.81	32.3	E100SS 0700 (grade)	
N100SS 1000 (grade)	1½"	1000	1700	5.91	1.77	20.67	11.81	48.4	E100SS 1000 (grade)	
N100SS 2000 (grade)	2"	2000	3400	5.91	1.77	32.48	19.69	61.6	E100SS 2000 (grade)	
N350SS (5000 psig)										
N350SS 0028 (grade)	¼"	28	48	1.61	0.39	4.06	2.36	3.5	E350SS 0028 (grade)	
N350SS 0067 (grade)	¼"	67	111	2.56	0.79	5.31	2.76	7.0	E350SS 0067 (grade)	
N350SS 0150 (grade)	½"	150	255	3.15	0.79	8.27	5.91	12.32	E350SS 0150 (grade)	
N350SS 0300 (grade)	¾"	300	510	3.15	0.98	11.02	5.91	13.42	E350SS 0300 (grade)	
N350SS 0445 (grade)	1"	445	750	5.91	1.38	12.99	7.87	31.9	E350SS 0445 (grade)	
N350SS 0775 (grade)	1"	775	1330	5.91	1.38	18.90	11.81	38.3	E350SS 0775 (grade)	

specifications	N50SS	N100SS	N350SS
design operating pressure range	0 to 725 psig	0 to 1450 psig	0 to 5000 psig
condensate drain (included)	manual ball valve		
filter housing material	316 stainless steel		

element performance	WS ⁽²⁾	M25	M5	M1	M01	AC
particle removal (microns)	-	25	5	1	0.01	-
max oil carry over at 68°F (ppm or mg/m ³)	-	10	5	0.1	0.01	0.003
recommended operating temp range	-	35 to 212°F	35 to 212°F	35 to 212°F	35 to 212°F	35 to 77°F
design operating temperature range	-	35 to 248°F	35 to 248°F	35 to 248°F	35 to 248°F	35 to 122°F

pressure correction factors									
N50SS (725 psig)									
operating pressure (psig)	60	90	120	150	220	290	435	580	725
correction factor	0.14	0.22	0.28	0.34	0.47	0.56	0.70	0.85	1.00
N100SS (1450 psig)									
operating pressure (psig)	290	435	580	725	870	1015	1160	1305	1450
correction factor	0.45	0.57	0.68	0.80	0.84	0.88	0.92	0.96	1.00
N350SS (5000 psig)									
operating pressure (psig)	725	1450	2175	2900	3625	4350	5000		
correction factor	0.73	0.78	0.82	0.87	0.91	0.96	1.00		

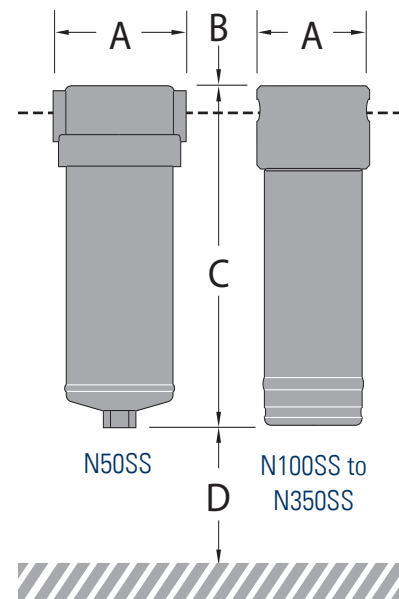

- (1) at 725, 1450 or 5000 psig as applicable. For all other pressures, refer to the pressure correction factor table above
- (2) install with air flow from inside to outside for coalescing and from outside to inside for dry dust filtration
- (3) differential pressure indicator not included
- (4) technical specifications subject to change without notice. Direct inquiries to support@n-psi.com or contact 704.897.2182